

HATCH SHOWER ACCESSORIES

Product Name: SELF-CLEANING HAND SHOWER SET
Model Number: HAT-SW013

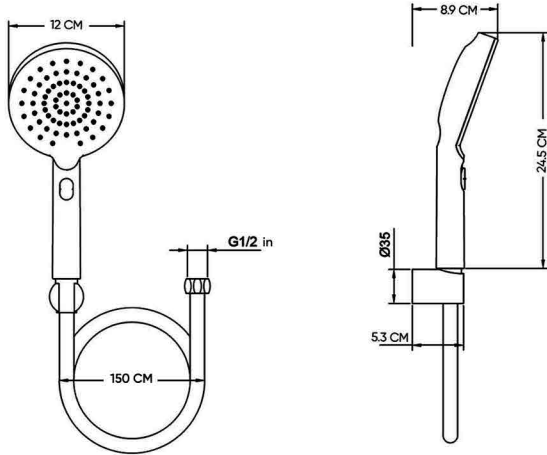

AVAILABLE COLORS



DESCRIPTIONS

Material: Plastic (ABS) Hand Shower and Holder, Hose material PVC
Shape: Round
Packaging unit: 1 set

TECHNICAL SPECIFICATION

Average Flow rate: 8.34 L/min
Maximum operating pressure: 10 bar
Water consumption: Class B
Self-Cleaning function: Yes
Spray mode
Mounting type: Exposed
Flow Regulator: Yes
Hose connection size: G ½ in
PVC 150 cm
Silicon Nozzles Easy to Clean

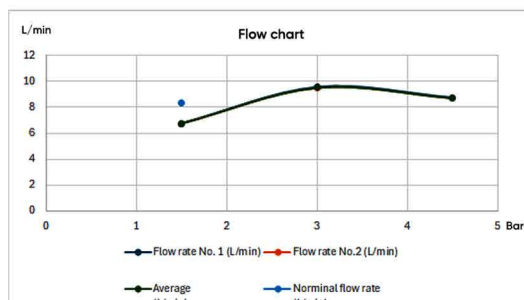

DIMENSION

24.5 x 12 x 150 CM

APPLICATIONS

Bathroom

BOX COMPONENTS

- Hand Shower
- Holder
- PVC Hose
- Rubber Gasket filter
- Fischer wall plug set
- (SUS 304) screws

COUNTRY OF ORIGIN

Made in China for HATCH Sanitary

WARRANTY

2 years



HATCH SANITARY

Hatch Sanitary is a trademark owned by MHG

Old Al Kharj Road, Building No. 3533
 Riyadh 14511 - 8305
 Kingdom of Saudi Arabia

info.mhg@marketing-home.com

800 122 2230