

HATCH TOUCHLESS WASHBASIN MIXER

Product Name: SENSOR WASHBASIN MIXER

Model Number: HAT-MX040

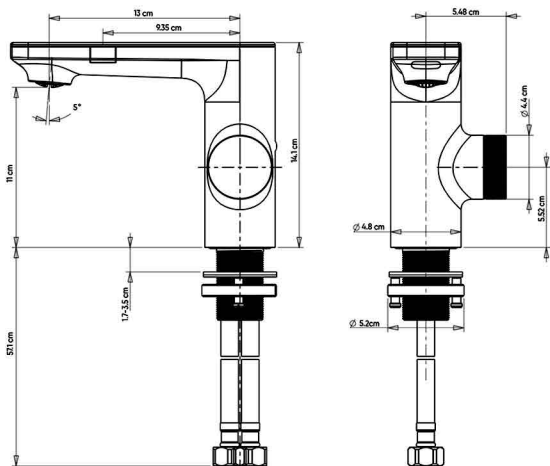

AVAILABLE COLORS



GLOSSY CHROME/WHITE
SW01530581



MATTE BLACK/WHITE
SW01530582



MATTE BLACK
SW01530583

DIMENSIONS

H 11 x D 13 x Ø 4.8 CM

DESCRIPTIONS

Material: Sensor Washbasin Mixer, Zinc main body and Handle
Projection: 13 cm
Spout height: 11 cm

TECHNICAL SPECIFICATION

Average Flow rate: 3.09 L/min
Spray type: Normal spray
Connection type: G ½ inch connections

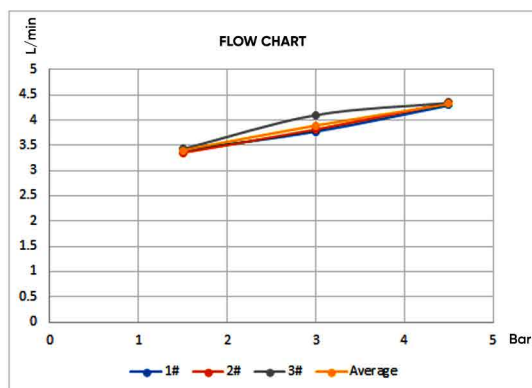

APPLICATIONS

Bathroom

BOX COMPONENTS

- Sensor Washbasin Mixer
- 2 Hoses (Hot & Cold)
- Fixing set
- (SUS 304) Screws
- Lock nut
- Aerator key
- Battery Box
- Allen Key

COUNTRY OF ORIGIN

Made in China for HATCH Sanitary

WARRANTY

5 years for function
2 years for surface



HATCH SANITARY

Hatch Sanitary is a trademark owned by MHG

Old Al Kharj Road, Building No. 3533
Riyadh 14511 - 8305
Kingdom of Saudi Arabia

© info.mhg@marketing-home.com

☎ 800 122 2230