

HATCH COUNTERTOP WASHBASIN MIXERS

Product Name: SINGLE LEVER WASHBASIN MIXER
Model Number: HAT-MX023

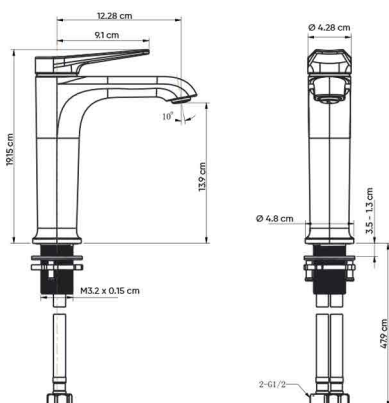

AGAINST MANUFACTURING DEFECTS FOR MIXER



AVAILABLE COLORS



GLOSSY CHROME
SW01530124



MATTE BLACK
SW01530584



BRUSHED NICKEL
SW01530157

DIMENSIONS

19.15 x 12.28 x 4.8 CM

DESCRIPTIONS

Material: Brass main body, Inlet Hose material: Nylon hose with brass nuts
Packaging unit: 1 piece

TECHNICAL SPECIFICATION

Average Flow rate: 3.65 L/min
 Maximum operating pressure: 15 bar
 Water consumption: Class A
 Spray type: Normal spray
 Inlet hose size: G ½ in
 Inlet hose length: 60 cm
 Mounting type: Countertop
 Projection: 12.28 cm
 Spout height: 13.9 cm
 Ceramic cartridge
 Aerator able to open, easy to clean

APPLICATIONS

Bathroom/Washroom

BOX COMPONENTS

- Single Lever Mixer
- 2 Hoses (Hot & Cold)
- Fixing set
- (SUS 304) Screws
- Aerator key

COUNTRY OF ORIGIN

Made in China for HATCH Sanitary

WARRANTY

5 years against manufacturing defects for mixer

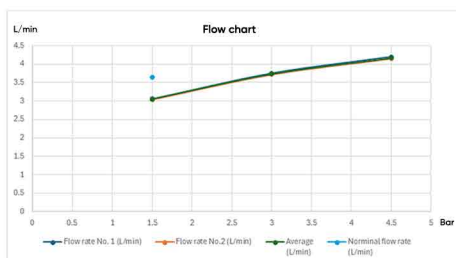

HATCH SANITARY

Hatch Sanitary is a trademark owned by MHG

Old Al Kharj Road, Building No. 3533
 Riyadh 14511 - 8305
 Kingdom of Saudi Arabia

info.mhg@marketing-home.com

800 122 2230