

HATCH COUNTERTOP WASHBASIN MIXERS

Product Name: SINGLE LEVER WASHBASIN MIXER
Model Number: HAT-MX022

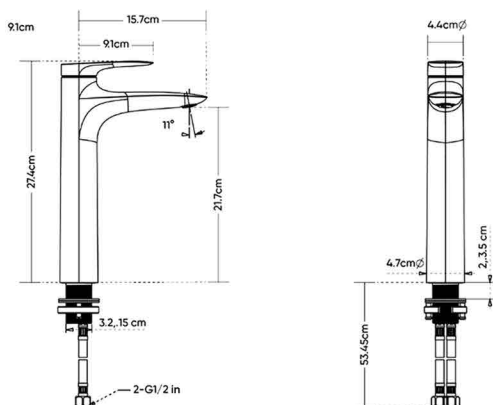

AVAILABLE COLORS



DESCRIPTIONS

Material: Brass main body, connection pipes, Inlet Hose material: Nylon with Brass nuts
Packaging unit: 1 piece

DIMENSIONS

27.4 x 15.7 x 4.4 CM

TECHNICAL SPECIFICATION

Average Flow rate: 3.65 L/min
 Maximum operating pressure: 15 bar
 Water consumption: Class A
 Spray type: Normal spray
 Inlet hose size: G ½ in
 Inlet hose length: 60 cm
 Mounting type: Countertop
 Projection: 15.7 cm
 Spout height: 21.7 cm
 Ceramic cartridge
 Aerator able to open, easy to clean

APPLICATIONS

Bathroom/Washroom

BOX COMPONENTS

- Single Lever Mixer
- 2 Hoses (Hot & Cold)
- Fixing set
- (SUS 304) Screws
- Aerator key

COUNTRY OF ORIGIN

Made in China for HATCH Sanitary

WARRANTY

5 years for function
 2 years for surface

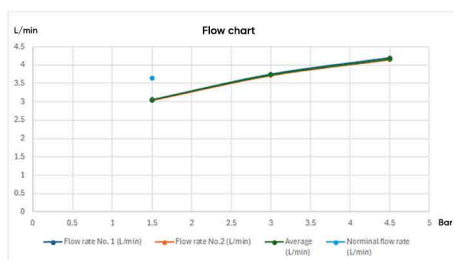

HATCH SANITARY

Hatch Sanitary is a trademark owned by MHG

Old Al Kharj Road, Building No. 3533
 Riyadh 14511 - 8305
 Kingdom of Saudi Arabia

© info.mhg@marketing-home.com

☎ 800 122 2230